

teg

Standalone Automatic Plate Flatness Tester

Machine Features

Features:

- Standalone Flatness Testing Machine,
- Separates Plates into two stacks (Pass/Reject)
- Requires Air (6Bar) and Power (240V),
- PLC Controlled,
- Fully Automated Testing,
- Fully Enclosed,
- Fully CE Marked.

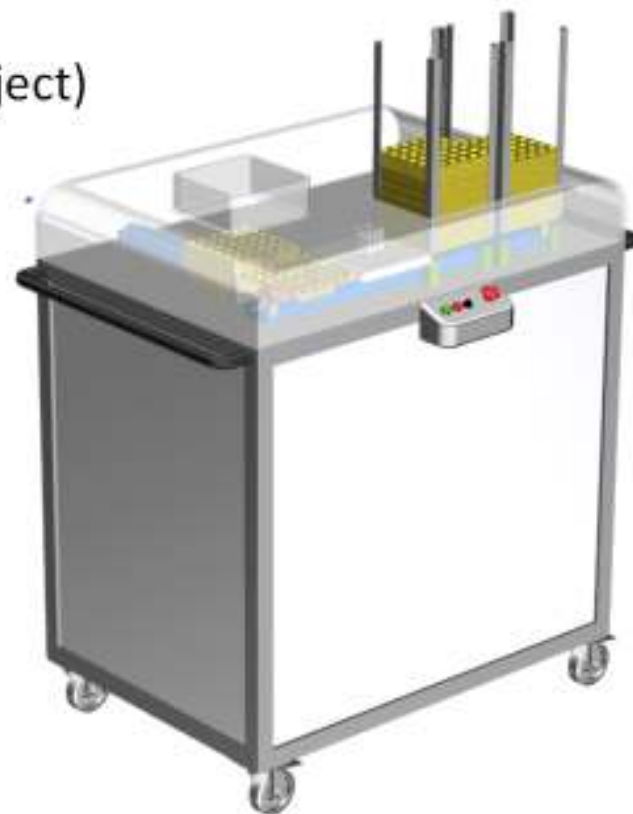

Machine Components

Overview

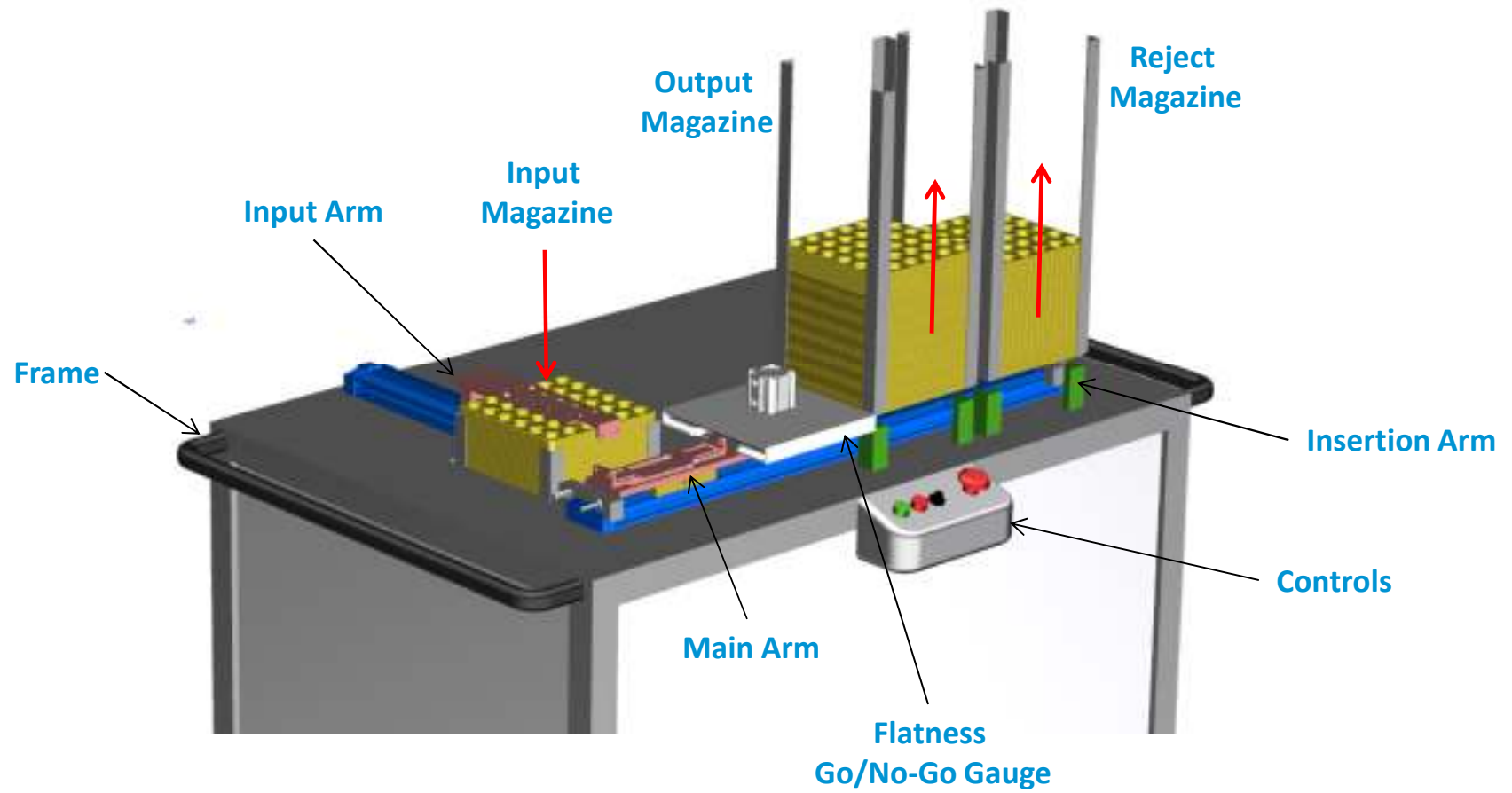

Sequence of Operation

Operation

1. Once the Input Magazine is loaded and Operator hits Start, The Input magazine lowers:
2. The Input Arm Indexes the Top Plate onto the Main Arm.

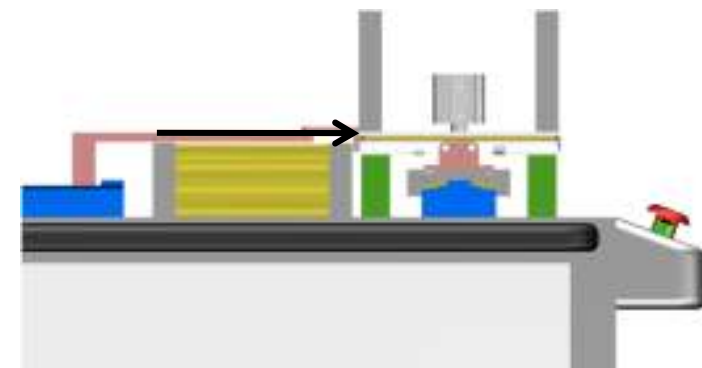
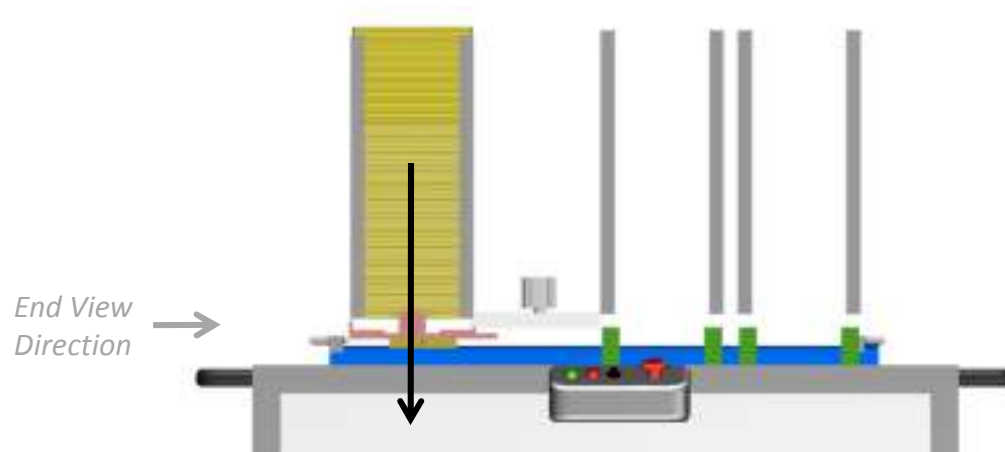

Sequence of Operation

3. The Main Arm Pushes the plate into the Go/No-go Gauge.

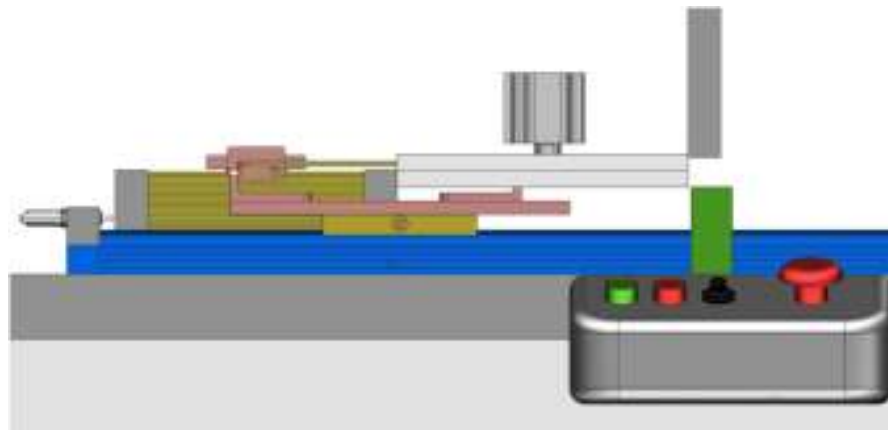

Sequence of Operation

Go

4. If the Plate is Flat it will pass through the Gauge and be inserted into the Output magazine by the Insertion Arm.

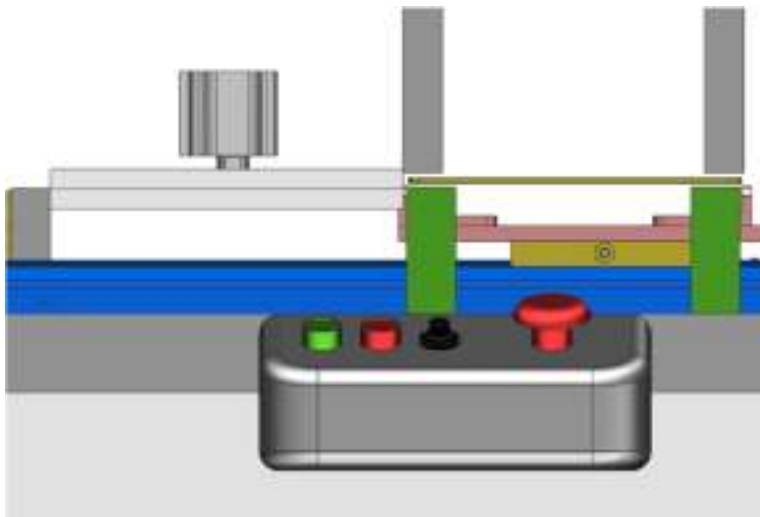

No-Go

4. If the Plate is not Flat it will not pass through the Gauge. This will be detected and the gauge opens to allow the plate to go to the Reject Magazine.

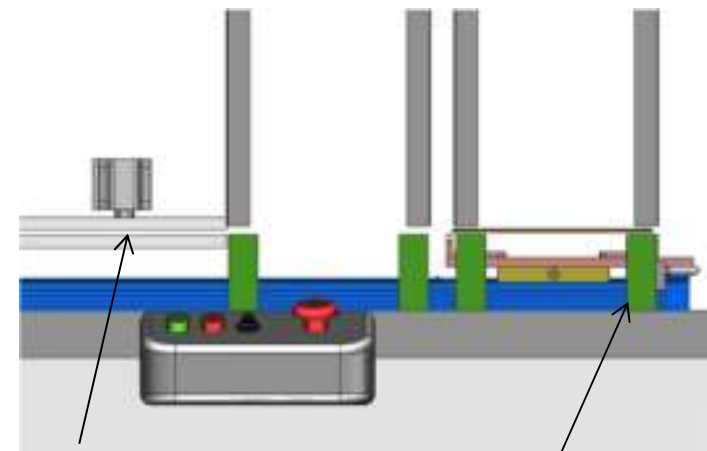

Gauge
Opens

Plate Inserted
into Reject Magazine

Sequence of Operation

5. Once the Plate is off loaded into the magazine, it lowers and returns Back to the input magazine to begin the cycle again.

